









INDEX

GENERAL INFORMATION	
	GEN INFO 1
SPECIFICATIONS	
	SPEC 2
PERIODIC INSPECTION AND ADJUSTMENT	
	INSP ADJ 3
ENGINE OVERHAUL	
	ENG 4
COOLING SYSTEM	
	COOL 5
CARBURETION	
	CARB 6
CHASSIS	
	CHAS 7
ELECTRICAL	
	ELEC 8
TROUBLESHOOTING	?
	TRBL SHTG 9

CHAPTER 2. SPECIFICATIONS

GENERAL SPECIFICATIONS2-1

MAINTENANCE SPECIFICATIONS2-5

 ENGINE2-5

 CHASSIS.....2-13

 ELECTRICAL.....2-17

GENERAL TORQUE SPECIFICATIONS2-20

DEFINITION OF UNITS2-20

LUBRICATION POINT AND GRADE OF LUBRICANT2-21

LUBRICATION DIAGRAM2-23

COOLANT DIAGRAM.....2-28

CABLE ROUTING.....2-29



SPECIFICATIONS

GENERAL SPECIFICATIONS

Model	XTZ750
Model Code Number:	3LD 3SC (E) 3TD (CH)
Frame Starting Number:	3LD-000101 3SC-000101 (E) 3TD-000101 (CH)
Engine Starting Number:	3LD-000101 3SC-000101 (E) 3TD-000101 (CH)
Dimensions:	
Overall Length	2,285 mm (90.0 in) (B)(F)(GB)(NL)(E)(I) 2,355 mm (92.7 in) (D)(S)(DK)(SF)(N)(CH)
Overall Width	815 mm (32.1 in)
Overall Height	1,355 mm (53.3 in)
Seat Height	865 mm (34.1 in)
Wheelbase	1,505 mm (59.3 in)
Minimum Ground Clearance	240 mm (9.5 in)
Basic Weight:	
With Oil and Full Fuel Tank	226 kg (498 lb)
Minimum Turning Radius:	2,400 mm (94.5 in)
Engine:	
Engine Type	Liquid cooled 4-stroke, DOHC
Cylinder Arrangement	Forward inclined parallel 2-cylinder
Displacement	749 cm ³
Bore × Stroke	87 × 63 mm (3.43 × 2.48 in)
Compression Ratio	9.5 : 1
Compression Pressure	950 kPa (9.5 kg/cm ² , 135 psi)
Starting System	Electric starter
Lubrication System:	Dry sump
Engine Oil Type or Grade:	<p>SAE 10W30 type SE motor oil</p> <p>SAE 20W40 type SE motor oil</p>

GENERAL SPECIFICATIONS

SPEC



Model	XTZ750	
Engine Oil Capacity: Periodic Oil Change: With Oil Filter Replacement Total Amount	4.0 L (3.5 Imp qt, 4.2 US qt) 4.1 L (3.6 Imp qt, 4.3 US qt) 4.4 L (3.9 Imp qt, 4.7 US qt)	
Coolant Total Amount: (Including All Routes)	1.7 L (1.5 Imp qt, 1.8 US qt)	
Air Filter:	Dry type element	
Fuel: Type Tank Capacity Reserve Amount	Regular gasoline 26 L (5.7 Imp qt, 6.9 US gal) 5 L (1.1 Imp qt, 1.3 US gal)	
Carburetor: Type × Quantity Manufacturer	BDST 38 × 2 MIKUNI	
Spark Plug: Type Manufacturer Gap	DPR8EA-9/X24EPRU-9 NGK/NIPPON DENSO 0.8 ~ 0.9 mm (0.031 ~ 0.035 in)	
Clutch Type:	Wet, multiple-disc	
Transmission: Primary Reduction System Primary Reduction Ratio Secondary Reduction System Secondary Reduction Ratio Transmission Type Operation Gear Ratio	Spur gear 67/39 (1.718) Chain Drive 46/16 (2.875) Constant mesh 5-speed Left foot operation 1st 37/13 (2.846) 2nd 37/20 (1.850) 3rd 30/21 (1.429) 4th 27/23 (1.174) 5th 28/27 (1.037)	
Chassis: Frame Type Caster Angle Trail	Double cradle 26.5° 101 mm (3.98 in)	
Tire:	Front	Rear
	Type Size Manufacturer (Type)	With tube 90/90-21 54H BRIDGESTONE (TW47)

GENERAL SPECIFICATIONS

SPEC



Model	XTZ750	
Tire Pressure (Cold Tire): Maximum load*	184 kg (406 lb)	
Cold tire pressure Up to 90 kg (198 lb) load*	Front	Rear
90 kg (198 lb) ~ Maximum load*	225 kPa (2.25 kg/cm ² , 33 psi)	225 kPa (2.25 kg/cm ² , 33 psi)
High speed riding	225 kPa (2.25 kg/cm ² , 33 psi)	250 kPa (2.5 kg/cm ² , 36 psi)
*Load is total weight of cargo, rider, passenger, and accessories.		
Brake: Front Brake Type Operation Rear Brake Type Operation	Dual disc brake Right hand operation Single disc brake Right foot operation	
Suspension: Front Suspension Rear Suspension	Telescopic fork Swingarm (Link suspension)	
Shock Absorber: Front Shock Absorber Rear Shock Absorber	Coil-Air spring/Oil damper Coil-Gas spring/Oil damper	
Wheel Travel: Front Wheel Travel Rear Wheel Travel	235 mm (9.25 in) 215 mm (8.46 in)	
Electrical: Ignition System Generator System Battery Type or Model Battery Capacity	T.C.I. (Digital) A.C. magneto generator YB14L-A 12V, 14AH	
Headlight Type:	Quartz bulb (Halogen)	
Bulb Wattage × Quantity: Headlight Auxiliary Light Tail/Brake Light Flasher Light	12V 55W + 12V 60/55W (D, F, B, S) 12V 45/40W × 2 (SF, NL, E, DK, N) 12V 35/35W × 2 (I, GB) 12V 4W × 1 (D, F, B, S, SF, NL) 12V 4W × 2 (E, DK, N) 12V 3W × 2 (I) 12V 3.4W × 2 (GB) 12V 5W/21W × 1 12V 21W × 4	

GENERAL SPECIFICATIONS

SPEC



Model	XTZ750	
Indicator Light: Wattage x Quantity	"METER LIGHT" "NEUTRAL" "HIGH BEAM" "TURN"	12V 3.4W x 2 12V 3.4W x 1 12V 3.4W x 1 12V 3.4W x 2

MAINTENANCE SPECIFICATIONS
ENGINE

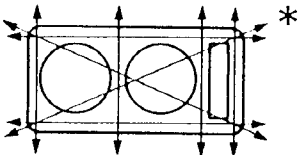
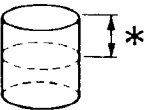
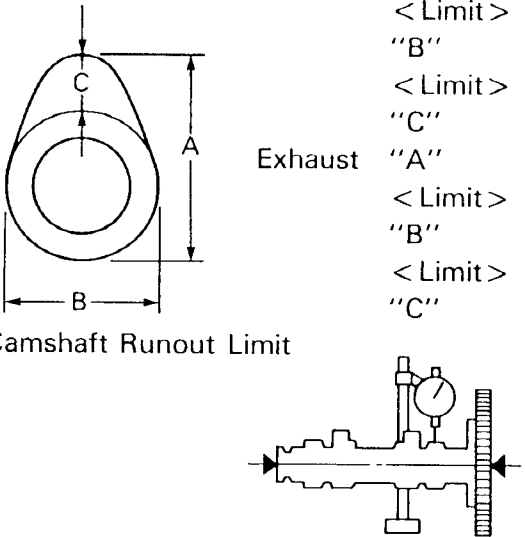
Model	XTZ750
<p>Cylinder Head: Warp Limit*</p> 	<p>0.03 mm (0.0012 in) * Lines indicate straightedge measurement.</p>
<p>Cylinder: Bore Size/Measuring Point*</p>  <p><Wear Limit></p>	<p>87.000 ~ 87.005 mm (3.4252 ~ 3.4254 in) 40 mm (1.6 in) 87.1 mm (3.429 in)</p>
<p>Camshaft: Drive Method Camshaft Outside Diameter Shaft-to-cap Clearance Cam Dimensions: Intake Exhaust Camshaft Runout Limit</p> 	<p>Chain drive (Right) 24.967 ~ 24.980 mm (0.9830 ~ 0.9835 in) 0.020 ~ 0.054 mm (0.0008 ~ 0.0021 in) 35.7 ~ 35.8 mm (1.4055 ~ 1.4094 in) < Limit > 35.6 mm (1.4 in) "B" 27.95 ~ 28.05 mm (1.1004 ~ 1.1043 in) < Limit > 27.85 mm (1.1 in) "C" 7.65 ~ 7.85 mm (0.3012 ~ 0.3091 in) Exhaust "A" 35.95 ~ 36.05 mm (1.4154 ~ 1.4193 in) < Limit > 35.85 mm (1.41 in) "B" 27.95 ~ 28.05 mm (1.1004 ~ 1.1043 in) < Limit > 27.85 mm (1.1 in) "C" 7.9 ~ 8.1 mm (0.3110 ~ 0.3189 in) 0.03 mm (0.0012 in)</p>
<p>Timing Chain: Chain Type/No. of Links Chain Adjustment Method</p>	<p>82 RH 2015/138 Links Automatic</p>

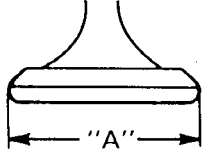
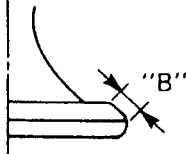
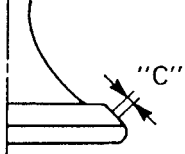
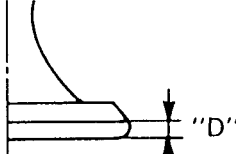
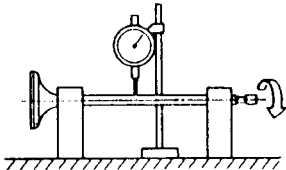

Model		XTZ750	
Valve, Valve Seat, Valve Guide: Valve Clearance (Cold):			
	IN.	0.15 ~ 0.20 mm (0.006 ~ 0.008 in)	
	EX.	0.25 ~ 0.30 mm (0.010 ~ 0.012 in)	
Valve Dimensions:			
			
Head Dia.	Face Width	Seat Width	Margin Thickness
"A" Head Dia.	IN.	25.9 ~ 26.1 mm (1.020 ~ 1.028 in)	
	EX.	27.9 ~ 28.1 mm (1.098 ~ 1.106 in)	
"B" Face Width	IN.	2.06 ~ 2.46 mm (0.081 ~ 0.097 in)	
	EX.	2.06 ~ 2.46 mm (0.081 ~ 0.097 in)	
"C" Seat Limit Width	IN.	0.9 ~ 1.1 mm (0.035 ~ 0.043 in)	
	EX.	0.9 ~ 1.1 mm (0.035 ~ 0.043 in)	
"D" Margin Thickness Limit	IN.	0.8 ~ 1.2 mm (0.032 ~ 0.047 in)	
	EX.	0.8 ~ 1.2 mm (0.032 ~ 0.047 in)	
Stem Outside Diameter	IN.	5.475 ~ 5.490 mm (0.2156 ~ 0.2161 in)	
	EX.	5.460 ~ 5.475 mm (0.2150 ~ 0.2156 in)	
< Limit >	IN.	5.45 mm (0.214 in)	
	EX.	5.43 mm (0.214 in)	
Guide Inside Diameter	IN.	5.50 ~ 5.51 mm (0.216 ~ 0.217 in)	
	EX.	5.50 ~ 5.51 mm (0.216 ~ 0.217 in)	
< Limit >	IN.	5.55 mm (0.219 in)	
	EX.	5.55 mm (0.219 in)	
Stem-to-Guide Clearance	IN.	0.01 ~ 0.04 mm (0.0004 ~ 0.0015 in)	
	EX.	0.03 ~ 0.05 mm (0.001 ~ 0.002 in)	
< Limit >	IN.	0.08 mm (0.003 in)	
	EX.	0.1 mm (0.004 in)	
Stem Runout Limit		0.01 mm (0.004 in)	
			
Valve Seat Width	IN.	0.9 ~ 1.1 mm (0.035 ~ 0.043 in)	
	EX.	0.9 ~ 1.1 mm (0.035 ~ 0.043 in)	

MAINTENANCE SPECIFICATIONS



Model	XTZ750
<p>Valve Spring:</p> <p>Free Length IN. EX.</p> <p>Set Length (Valve Closed) IN. EX.</p> <p>Compressed Pressure (Valve Closed) IN. EX.</p> <p>Tilt Limit IN. EX.</p> <div style="text-align: center; margin: 10px 0;"> </div> <p>Direction of Winding (Top View) IN. EX.</p>	<p>37.29 mm (1.47 in) 37.29 mm (1.47 in)</p> <p>30.39 mm (1.2 in) 30.39 mm (1.2 in)</p> <p>10.00 ~ 11.60 kg (22.05 ~ 22.57 lb) at 30.39 mm 10.00 ~ 11.60 kg (22.05 ~ 22.57 lb) at 30.39 mm</p> <p>2.5°/1.7 mm (2.5°/0.067 in) 2.5°/1.7 mm (2.5°/0.067 in)</p> <p>Clockwise Clockwise</p>
<p>Piston:</p> <p>Piston Size "D" Measuring Point "H"</p> <div style="text-align: center; margin: 10px 0;"> </div> <p>Piston Off-set Piston Off-set Direction Piston-to-Cylinder Clearance <Limit ></p>	<p>86.920 ~ 86.935 mm (3.422 ~ 3.423 in) 4.7 mm (0.185 in)</p> <p>1 mm (0.04 in) INSIDE 0.065 ~ 0.085 mm (0.0026 ~ 0.0033 in) < 0.15 mm (0.0059 in) ></p>
<p>Piston Ring:</p> <p>Top Ring:</p> <p>Type Dimensions (B × T) End Gap (Installed)</p> <div style="text-align: center; margin: 10px 0;"> </div> <p>Side Clearance (Installed)</p> <p>2nd Ring:</p> <p>Type Dimensions (B × T) End Gap (Installed)</p> <div style="text-align: center; margin: 10px 0;"> </div> <p>Side Clearance</p> <p>Oil Ring:</p> <p>Dimensions (B × T) End Gap (Installed)</p> <div style="text-align: center; margin: 10px 0;"> </div>	<p>Barrel 1.0 × 3.3 mm (0.039 × 0.130 in) 0.3 ~ 0.5 mm (0.012 ~ 0.020 in)</p> <p>0.03 ~ 0.07 mm (0.0012 ~ 0.0028 in)</p> <p>Taper 1.0 × 3.3 mm (0.039 × 0.130 in) 0.3 ~ 0.5 mm (0.012 ~ 0.020 in)</p> <p>0.02 ~ 0.06 mm (0.0008 ~ 0.0024 in)</p> <p>2.0 × 2.8 mm (0.079 × 0.110 in) 0.2 ~ 0.7 mm (0.008 ~ 0.028 in)</p>

MAINTENANCE SPECIFICATIONS

SPEC

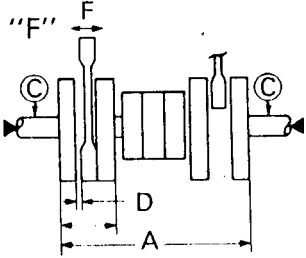

Model	XTZ750
Connecting Rod: Oil Clearance Bearing Color Code	0.026 ~ 0.050 mm (0.001 ~ 0.002 in) 1. Blue 2. Black 3. Brown 4. Green
Crankshaft: Crank Width "A" Runout Limit "C" Big End Side Clearance "D" Small End Free Play "F"  Oil Clearance Bearing Color Code	64.75 ~ 65.25 mm (2.549 ~ 2.569 in) 0.02 mm (0.0008 in) 0.16 ~ 0.27 mm (0.006 ~ 0.011 in) 0.8 ~ 1.0 mm (0.0315 ~ 0.0394 in) 0.020 ~ 0.038 mm (0.0007 ~ 0.0015 in) 1. Blue 2. Black 3. Brown, 4. Green 5. Yellow 6. Pink 7. Red
Balancer: Drive Method	Spur gear
Clutch: Friction Plate: Thickness Quantity Wear Limit Clutch Plate: Thickness Quantity Warp Limit Clutch Plate: Thickness Quantity Warp Limit Clutch Spring: Free Length Quantity Minimum Free Length Clutch Release Method	2.9 ~ 3.1 mm (0.114 ~ 0.122 in) 8 pcs. 2.8 mm (0.11 in) 2.2 ~ 2.4 mm (0.087 ~ 0.094 in) 1 pc. 0.1 mm (0.004 in) 1.9 ~ 2.1 mm (0.075 ~ 0.083 in) 7 pcs. 0.1 mm (0.004 in) 51.8 mm (2.04 in) 6 pcs. 50 mm (1.97 in) Outer pull, rack & pinion pull
Transmission: Main Axle Runout Limit Drive Axle Runout Limit	0.08 mm (0.003 in) 0.08 mm (0.003 in)
Shifter: Type	Guide bar

MAINTENANCE SPECIFICATIONS

SPEC



Model	XTZ750
Carburetor: I.D. Mark Main Jet (M.J.) Main Air Jet (M.A.J.) Jet Needle (J.N.) Needle Jet (N.J.) Throttle Valve Size (Th.V.) Pilot Jet (P.J.) Pilot Air Jet (P.A.J.) Bypass 1 (B.P.1) 2 (B.P.2) 3 (B.P.3) Pilot Screw (P.S.) Valve Seat (V.S.) Starter Jet 1 (G.S.1) 2 (G.S.2) Pilot Outlet (P.O.) Fuel Level Engine Idling Speed Vacuum Pressure at Idling Speed	3LD 00, 3TD 00 (CH) #142.5, #140 (CH) #60 5C19-3, 5C20-3 (CH) Y-4 (611) #130 #42.5, #35 (CH) #60 φ0.8 φ0.8 φ0.8 2 turns out φ1.7 #70 φ0.8 φ0.85, φ0.9 (CH) 5.1 ~ 6.1 mm (0.2 ~ 0.24 in) Above from the float chamber line 1,100 ~ 1,200 r/min 31.9 ~ 34.6 kPa (240 ~ 260 mmHg, 8.1 ~ 8.8 inHg)
Lubrication System: Oil Filter Type Oil Pump Type Tip Clearance Side Clearance Bypass Valve Setting Pressure Relief Valve Operating Pressure	Paper type Trochoid pump type 0 ~ 0.12 mm (0 ~ 0.005 in) 0.03 ~ 0.08 mm (0.001 ~ 0.003 in) 40 ~ 80 kPa (0.4 ~ 0.8 kg/cm ² , 5.69 ~ 11.38 psi) 350 ~ 450 kPa (3.5 ~ 4.5 kg/cm ² , 49.77 ~ 63.99 psi)
Cooling System: Radiator Core Size Width Height Thickness Radiator Cap Opening Pressure Reservoir Tank Capacity <From Low to Full Level> Water Pump Type Reduction Ratio Thermostat Opening Temperature	380 mm (15 in) 147.8 mm (5.82 in) 32 mm (1.26 in) 95 ~ 125 kPa (0.95 ~ 1.25 kg/cm ² , 13.51 ~ 17.77 psi) 0.45 L (0.40 Imp qt, 0.47 US qt) <0.15 L (0.13 Imp qt, 0.16 US qt)> Single-suction centrifugal pump 44/44 × 38/27 (1.407) 80 ~ 84°C (176 ~ 183°F)

MAINTENANCE SPECIFICATIONS

SPEC







TIGHTENING TORQUE

Part to be tightened	Part name	Thread size	Q'ty	Tightening torque			Remarks
				Nm	m•kg	ft•lb	
Cylinder head (exhaust pipe)	Stud bolt	M 8	4	15	1.5	11	
Cylinder head (camshaft cap)	Flange bolt	M 6	16	10	1.0	7.2	
Cylinder head	Nut	M10	6	40	4.0	29	
Cylinder head cover	Bolt	M 6	4	10	1.0	7.2	
Cylinder body drain bolt	Flange bolt	M 6	1	10	1.0	7.2	
Spark plug	—	M12	2	17.5	1.75	12.5	
Connecting rod	Nut	M 9	4	48	4.8	35	
Flywheel magneto	Flange bolt	M12	1	130	13	94	
Timing chain sprocket	Flange bolt	M 7	4	24	2.4	17	
Timing chain tensioner	Bolt	M 6	1	10	1.0	7.2	
Thermostat	Flange bolt	M16	1	13	1.3	9.4	
Hose clamp (thermostat-radiator)	Panhead screw	M 5	2	2	0.2	1.4	
(cylinder-thermostat)	Panhead screw	M 5	2	2	0.2	1.4	
(radiator-water pump)	Panhead screw	M 5	2	2	0.2	1.4	
Radiator protector	Panhead screw	M 5	4	5	0.5	3.6	
Radiator	Flange bolt	M 6	2	7	0.7	5.1	
Delivery hose (crankcase-cylinder)	Bolt	M10	2	21	2.1	15	
Oil pump assembly	Panhead screw	M 6	6	6	0.6	4.3	
Oil baffle plate	Flange bolt	M 6	2	10	1.0	7.2	
Drain plug (oil pan)	—	M14	1	35	3.5	25	
Oil strainer	Panhead screw	M 6	4	7	0.7	5	Stake
Relief valve stay	Flange bolt	M 6	1	10	1.0	7.2	
Drain bolt (oil strainer case)	Flange bolt	M10	1	30	3.0	22	
Carburetor joint	Bolt	M 6	4	10	1.0	7.2	
Air cleaner	Flange bolt	M 6	1	7	0.7	5.1	
Muffler protector	Screw	M 6	8	4	0.4	2.9	
Exhaust pipe (CO test)	Bolt	M 6	2	10	1.0	7.2	
Exhaust pipe	Nut	M 8	4	20	2.0	14	
Exhaust pipe protector	Screw	M 6	3	4	0.4	2.9	
Exhaust pipe and muffler	Bolt	M 8	2	20	2.0	14	
Muffler	Bolt	M 8	2	24	2.4	17	
Crankcase	Flange bolt	M10	6	40	4.0	29	
Crankcase	Flange bolt	M 6	10	12	1.2	8.7	
Crankcase	Flange bolt	M 8	11	24	2.4	17	
Balancer shaft	Screw	M 6	2	12	1.2	8.7	
Holder	Flange bolt	M 6	4	10	1.0	7.2	
Chain cover	Flange bolt	M 6	2	5	0.5	3.6	
Crankcase cover (left-rear)	Flange bolt	M 6	5	5	0.5	3.6	

MAINTENANCE SPECIFICATIONS

SPEC



Part to be tightened	Part name	Thread size	Q'ty	Tightening torque			Remarks
				Nm	m•kg	ft•lb	
Crankcase cover (left-front)	Panhead screw	M 5	2	4	0.4	2.9	Stake 
Starter clutch	Bolt	M 6	3	10	1.0	7.2	
Clutch spring	Screw	M 6	6	8	0.8	5.8	
Clutch boss	Nut	M20	1	7	0.7	5.1	Use lock washer
Main axle bearing stopper	Screw	M 6	3	12	1.2	8.7	
Drive sprocket	Nut	M18	1	70	7.0	51	Use lock washer
Drive axle cover plate	Bolt	M 6	5	7	7.0	5.1	
Shift cam	Screw	M 5	1	4	0.4	2.9	
Shift cam stopper lever	Bolt	M 6	1	12	1.2	8.7	
Shift fork guide	Flange bolt	M 6	2	12	1.2	8.7	
Shift arm	Flange bolt	M 6	1	12	1.2	8.7	
Shift rod	Nut	M 6	2	8	0.8	5.8	
Stopper lever	Bolt	M 8	1	22	2.2	16	
Crankcase	Screw	M 6	1	12	1.2	8.7	
Stator	Screw	M 6	3	7	0.7	5.1	
Stator assembly sensor	Screw	M 5	2	4	0.4	2.9	
Ignition coil	Screw	M 6	2	10	1.0	7.2	
Neutral switch	Screw	M 6	2	4	0.4	2.9	
Starter motor	Flange bolt	M 6	2	10	1.0	7.2	
Thermo switch	—	M 6	1	28	2.8	20	
Thermo switch housing	—	PT 1/8	1	15	1.5	11	
Other engine part	Flange bolt	M 6	—	10	1.0	7.2	
	Screw	M 6	—	7	0.7	5	
	Flange bolt	M 8	—	20	2.0	14	



Model

XTZ750

Lubrication Chart:

➔ Pressured feed
➔ Splashed

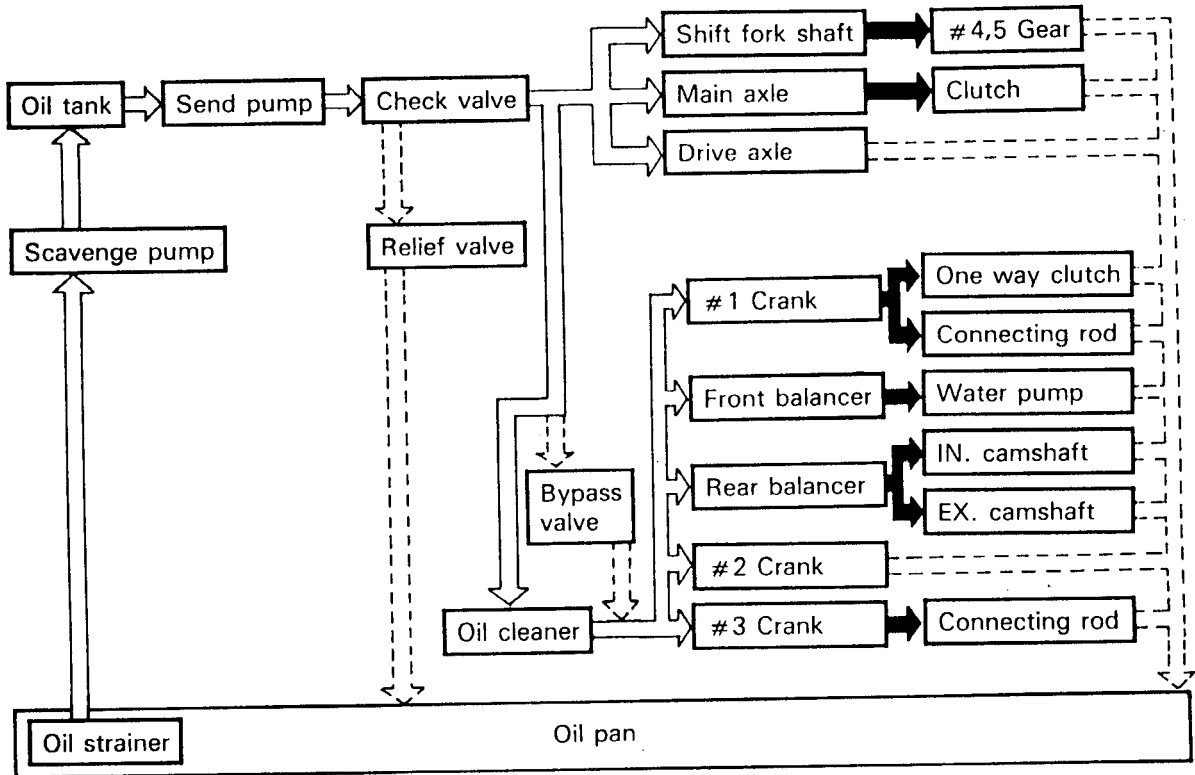

Crankcase Tightening Sequence:

Crankcase (Upper)

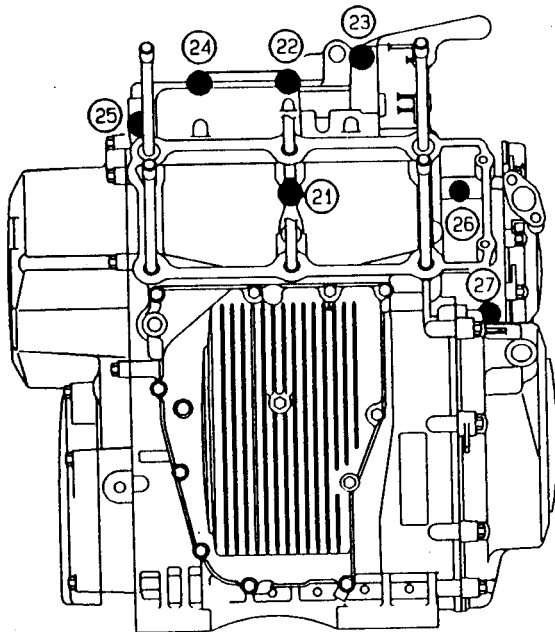

Crankcase (Lower)

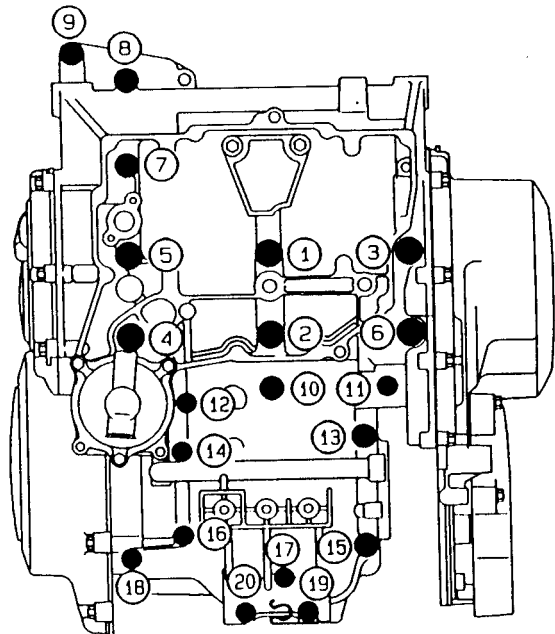

CHASSIS

Model	XTZ750
Steering System: Steering Bearing Type	Taper Roller Bearing
Front Suspension: Front Fork Travel Front Spring Free Length < Limit > Spring Rate: K1 Stroke K1 Optional Spring Oil Capacity Oil Level Oil Grade Enclosed Air Pressure: Standard	235 mm (9.25 in) 544.5 mm (21.4 in) < 517 mm (20.4 in) > 4.5 N/mm (0.45 kg/mm, 25.2 lb/in) 0.0 ~ 235 mm (0.0 ~ 9.25 in) No 669 cm ³ (23.5 Imp oz, 22.6 US oz) 130 mm (5.12 in) From top of inner tube fully compressed without spring. Fork oil 10W or equivalent 100 kPa (1 kg/cm ² , 14.2 psi)
Rear Suspension: Shock Absorber Travel Spring Free Length Fitting Length Spring Rate K1 Stroke K1 Optional Spring Enclosed Gas Pressure: Standard	82 mm (3.23 in) 240 mm (9.45 in) 457 mm (18 in) 140 N/mm (14.0 kg/mm, 784 lb/in) 0.0 ~ 82.0 mm (0.0 ~ 3.2 in) No 2,000 kPa (20 kg/cm ² , 284 psi)
Swingarm: Free Play Limit Side Clearance	1.0 mm (0.039 in) at swingarm end Move swingarm end side to side 0.3 mm (0.012 in) at swingarm pivot
Front Wheel: Type Rim Size Rim Material Rim Runout Limit Radial Lateral	Spoke wheel 1.85 × 21 Aluminum 1.0 mm (0.039 in) 0.5 mm (0.020 in)
Rear Wheel: Type Rim Size Rim Material Rim Runout Limit Radial Lateral	Spoke wheel MT3.00 × 17 Aluminum 1.0 mm (0.039 in) 0.5 mm (0.020 in)
Drive Chain: Type/Manufacturer No. of Links Chain Free Play	520VL2/DAIDO 112 25 ~ 35 mm (0.98 ~ 1.38 in)



TIGHTENING TORQUE

Part to be tightened	Thread size	Tightening torque			Remarks
		Nm	m•kg	ft•lb	
Handle crown and inner tube	M 8	23	2.3	17	See Note
Handle crown and steering shaft	M14	80	8.0	58	
Handlebar holder (upper) and handlebar holder (under)	M 8	20	2.0	14	
Steering shaft and ring nut	M25	5.5	0.55	4	
Cowling stay and frame	M 8	15	1.5	11	
Cowling stay and cowling (front)	M 6	7	0.7	5.1	
Cowling stay and ignitor unit	M 6	7	0.7	5.1	
Frame and rectifier/regulator	M 6	7	0.7	5.1	
Cowling stay and conduction unit	M*6	7	0.7	5.1	
Cowling stay and horn	M 6	7	0.7	5.1	
Cowling (front) and side cowling (left and right)	M 5	5	0.5	3.6	
Side cowling (left and right) and fuel tank	M 5	5	0.5	3.6	
Under bracket and joint	M6	7	0.7	5.1	
Front master cylinder and master cylinder cap	M 4	1.5	0.15	1	
Speedometer and cowling stay	M 6	7	0.7	5.1	
Handle crown and main switch	M 6	7	0.7	5.1	
Handlebar holder (under) and nut	M10	27	2.7	19	
Engine mounting and frame	M10	58	5.8	42	
Frame and down tube (front)	M 8	23	2.3	17	
Frame and down tube (rear-left)	M10	32	3.2	23	
Frame and down tube (rear-right)	M 8	23	2.3	17	
Engine protector and frame	M 6	7	0.7	5.1	
Pivot shaft and frame	M16	90	9.0	65	
Swingarm and relay arm	M14	50	5.0	36	
Relay arm and connecting rod	M14	50	5.0	36	
Connecting rod and rear arm	M14	50	5.0	36	
Rear shock absorber and frame	M10	35	3.5	25	
Rear shock absorber and relay arm	M10	35	3.5	25	
Chain tensioner	M 8	23	2.3	17	
Chain case and swingarm	M 6	4	0.4	2.9	
Chain protector and swingarm	M 6	7	0.7	5.1	
Chain guide and swingarm	M 6	7	0.7	5.1	
Fuel tank bracket and fuel tank	M 6	7	0.7	5.1	
Fuel tank bracket and frame	M 8	15	1.5	11	
Fuel tank and frame	M 6	7	0.7	5.1	
Fuel pump and frame	M 6	7	0.7	5.1	
Ignition coil and frame	M 6	7	0.7	5.1	
Rear carrier (front) and frame	M 8	20	2.0	14	
Rear carrier (rear) and frame	M 6	10	1.0	7.2	
Rear side cover and rear carrier	M 5	4	0.4	2.9	
Rear carrier and flasher bracket	M 6	7	0.7	5.1	
Helmet holder and flasher bracket	M 6	7	0.7	5.1	
Seat and frame	M 6	7	0.7	5.1	
Fuel cock and fuel tank	M 6	5	0.5	3.6	
Frame and battery box	M 6	7	0.7	5.1	



Part to be tightened	Thread size	Tightening torque			Remarks
		Nm	m•kg	ft•lb	
Mud guard and frame	M 6	7	0.7	5.1	
Oil tank and frame	M 6	7	0.7	5.1	
Side cover and frame	M 6	4	0.4	2.9	
Recovery tank and frame	M 6	6	0.6	4.3	
License bracket and frame	M 8	8	0.8	5.8	
License bracket and tail/brake light	M 6	7	0.7	5.1	
Rear reflector and stay	M 5	4	0.4	2.9	
License bracket number plate stay	M 6	4	0.4	2.9	
Front wheel axle and nut	M14	100	10.0	72	
Rear wheel axle and nut	M16	90	9.0	6.5	
Brake caliper (front) and front fork	M10	35	3.5	25	
Brake caliper (rear) and bracket	M10	35	3.5	25	
Sidestand and frame	M10	40	4.0	29	
Footrest bracket and frame	M10	45	4.5	32	
Footrest (for passenger) and frame	M 8	20	2.0	14	
Master cylinder (rear brake) and frame	M 8	20	2.0	14	
Reservoir tank (rear brake) and frame	M 6	4	0.4	2.9	
Sidestand switch and frame	M 5	4	0.4	2.9	
Brake hose (union bolt)	M10	25	2.5	18	
Brake hose and brake hose holder	M10	18	1.8	13	

NOTE:

1. First, tighten the ring nut approximately 38 Nm (3.8 m•kg, 27 ft•lb) by using the torque wrench, then loosen the ring nut one turn.
2. Retighten the ring nut to specification.

MAINTENANCE SPECIFICATIONS

SPEC



ELECTRICAL

Model	XTZ750
Voltage Ignition System: Ignition Timing (B.T.D.C.) Advanced Timing (B.T.D.C.) Advancer Type	12V 10° at 1,150 r/min 43° at 6,000 r/min Electrical type
<p style="text-align: center;">Ignition Timing (B.T.D.C.)</p> <p style="text-align: center;">Engine Speed (× 10³ r/min)</p>	
T.C.I.: Pickup Coil Resistance (Color) T.C.I. Unit/Manufacturer	184 ~ 276Ω at 20°C (68°F) (Blue/Yellow – Green/White) TNDF06/NIPPON DENSO
Ignition Coil: Model/Manufacturer Minimum Spark Gap Primary Winding Resistance Secondary Winding Resistance Spark Plug Cap: Type Resistance	JO246/NIPPON DENSO 6 mm (0.24 in) 2.38 ~ 3.22Ω at 20°C (68°F) 12 ~ 18 kΩ at 20°C (68°F) Resin type 10 kΩ at 20°C (68°F)
Charging System: Type	A.C. magneto generator



Model	XTZ750																						
<p>A.C. Generator: Model/Manufacturer Nominal Output</p>	<p>TLNZ29/NIPPON DENSO 14V 25A at 5,000 r/min</p> <div data-bbox="396 358 1085 805" data-label="Figure"> <table border="1"> <caption>Graph Data: Output Current vs Engine Speed</caption> <thead> <tr> <th>Engine Speed (x 10³ r/min)</th> <th>Output Current (A)</th> </tr> </thead> <tbody> <tr><td>1</td><td>4</td></tr> <tr><td>2</td><td>18</td></tr> <tr><td>3</td><td>22</td></tr> <tr><td>4</td><td>24</td></tr> <tr><td>5</td><td>25</td></tr> <tr><td>6</td><td>25</td></tr> <tr><td>7</td><td>25</td></tr> <tr><td>8</td><td>25</td></tr> <tr><td>9</td><td>25</td></tr> <tr><td>10</td><td>25</td></tr> </tbody> </table> </div>	Engine Speed (x 10 ³ r/min)	Output Current (A)	1	4	2	18	3	22	4	24	5	25	6	25	7	25	8	25	9	25	10	25
Engine Speed (x 10 ³ r/min)	Output Current (A)																						
1	4																						
2	18																						
3	22																						
4	24																						
5	25																						
6	25																						
7	25																						
8	25																						
9	25																						
10	25																						
Stator Coil Resistance	0.20 ~ 0.30Ω at 20°C (68°F) (White—White)																						
<p>Rectifier/Regulator: Model/Manufacturer Type Voltage Regulator No load Regulated Voltage Rectifier Capacity Withstand Voltage</p>	<p>SH569/SINDENGEN Semi conductor—Short circuit type 14.3 ~ 15.3V 25A 240V</p>																						
Battery:																							
Specific Gravity	1.280																						
<p>Electrical Starter System: Type Starter Motor: Model/Manufacturer Output Brush—Overall Length < Limit > Commutator Dia. Wear Limit Mica Undercut Starter Relay: Model/Manufacturer Amperage Rating</p>	<p>Constant mesh type SM-13/MITSUBA 0.8 kW 12.5 mm (0.49 in) < 5 mm (0.20 in) > 28.0 mm (1.10 in) 27.0 mm (1.06 in) 0.7 mm (0.028 in) MS5D-191/HITACHI 100A</p>																						
Horn:																							
Type/Quantity	Plane type/1 pc.																						
Model/Manufacturer	YF-12/NIKKO																						
Maximum Amperage	2.5A																						

MAINTENANCE SPECIFICATIONS

SPEC



Model	XTZ750
Flasher Relay (Relay Assembly): Type Model/Manufacturer Self Cancelling Device Flasher Frequency Wattage	Condenser type FZ249SD/NIPPON DENSO No 60 ~ 120 cyl/min 21W × 4 + 3.4W
Starting Circuit Cut-Off Relay: Model/Manufacturer Coil Winding Resistance Diode	G8MS/OMRON 90 ~ 110Ω Yes
Headlight Relay (F): Model/Manufacturer Coil Winding Resistance Diode	ACA1211-9/MATUSHITA 72 ~ 88Ω No
Electric Fan: Model/Manufacturer	NAAF48/NIPPON DENSO
Thermostat Switch: Model/Manufacturer Function Temperature	VF105A/N. THERMOSTAT 102 ~ 108°C (215.6 ~ 226.4°F): ON 98°C (208.4°F): OFF
Thermo Unit: Model/Manufacturer Coil Winding Resistance	11H/NIPPON SEIKI 153.9Ω at 50°C (122°F) 47.5 ~ 52.8Ω at 80°C (176°F) 26.2 ~ 29.3Ω at 100°C (212°F) 16.1Ω at 120°C (248°F)
Circuit Breaker: Type Amperage for Individual Circuit × Quantity: MAIN RESERVE	Fuse 30A/1 pc. 30A/1 pc.

GENERAL TORQUE SPECIFICATIONS

This chart specifies torque for standard fasteners with standard I.S.O. pitch threads. Torque specifications for special components or assemblies are included in the applicable sections of this book. To avoid warpage, tighten multi-fastener assemblies in a crisscross fashion, in progressive stages, until full torque is reached. Unless otherwise specified, torque specifications call for clean, dry threads. Components should be at room temperature.

A (Nut)	B (Bolt)	General torque specifications		
		Nm	m·kg	ft·lb
10 mm	6 mm	6	0.6	4.3
12 mm	8 mm	15	1.5	11
14 mm	10 mm	30	3.0	22
17 mm	12 mm	55	5.5	40
19 mm	14 mm	85	8.5	6.1
22 mm	16 mm	130	13.0	94

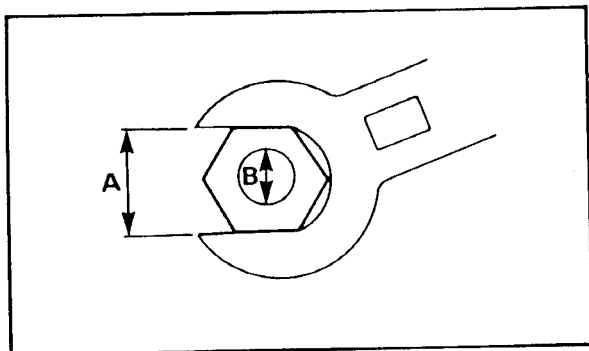

A: Distance across flats
B: Outside thread diameter

DEFINITION OF UNITS

Unit	Read	Definition	Measure
mm	millimeter	10^{-3} meter	Length
cm	centimeter	10^{-2} meter	Length
kg	kilogram	10^3 gram	Weight
N	Newton	$1 \text{ kg} \times \text{m}/\text{sec}^2$	Force
Nm	Newton meter	$\text{N} \times \text{m}$	Torque
m·kg	Meter kilogram	$\text{m} \times \text{kg}$	Torque
Pa	Pascal	N/m^2	Pressure
N/mm	Newton per millimeter	N/mm	Spring rate
L	Liter	—	Volume
cm^3	Cubic centimeter	—	or capacity
r/min	Rotation per minute	—	Engine speed

LUBRICATION POINT AND GRADE OF LUBRICANT

SPEC



LUBRICATION POINT AND GRADE OF LUBRICANT ENGINE











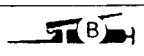

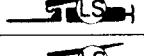





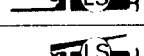
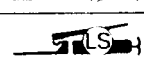

Lubrication Point	Lubricant Type
Oil seal lips	
O-ring	
Bearing	
Piston surface	
Piston pin	
Connecting rod bolt	
Crankshaft journal	
Balancer (Bearing/shaft)	
Camshaft cam lobe/journal	
Valve stem (IN. EX.)	
Valve stem end	
Water pump impeller shaft	
Oil pump rotor (Inner/outer) shaft	
Oil strainer assembly	
Crankcase cover (Push rod)	
Idle gear surface	
Starter clutch ball	
Primary driver gear	
Transmission gear (Wheel/pinion)	
Axle (Main/drive)	
Shift cam	
Shift fork/guide bar	
Shift shaft assembly	
Shift boss (Inner)	
Matching surface (Cylinder head and cylinder head cover)	Yamaha Bond No. 1215
Crankcase matching surface	Yamaha Bond No. 1215

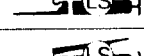
LUBRICATION POINT AND GRADE OF LUBRICANT

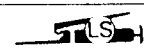
SPEC



CHASSIS

Lubrication Point	Lubricant Type
Gear unit (Speedometer)	
Front wheel oil seal lips	
Rear wheel oil seal lips	
Bush (Swingarm) and thrust cover	
Oil seal lips (Swingarm) and bearing	
Pivot shaft (Swingarm)	
Bearing (Relay arm and rear shock absorber)	
Bearing (Relay arm and frame)	
Bearing (Relay arm and connecting rod)	
Bearing (Connecting rod and swingarm)	
Brake pedal shaft	
Bearing (Steering head)	
Tube guide (Throttle grip) inner surface	
Brake lever, sliding surface	
Clutch lever, sliding surface	
Clutch cable end	
Side stand bolt, sliding surface	
Bush (Chain tensioner)	
Grease nipple (Swingarm)	
Grease nipple (Relay arm)	
Grease nipple (Relay arm and connecting rod)	
Grease nipple (Connecting rod and swingarm)	
Brake pedal and rear master cylinder	

LUBRICATION DIAGRAM

- ① Oil tank
- ② Oil strainer
- ③ Oil pump
- ④ Oil cleaner
- [B] From crankcase
- [C] To crankshaft
- [D] To transmission

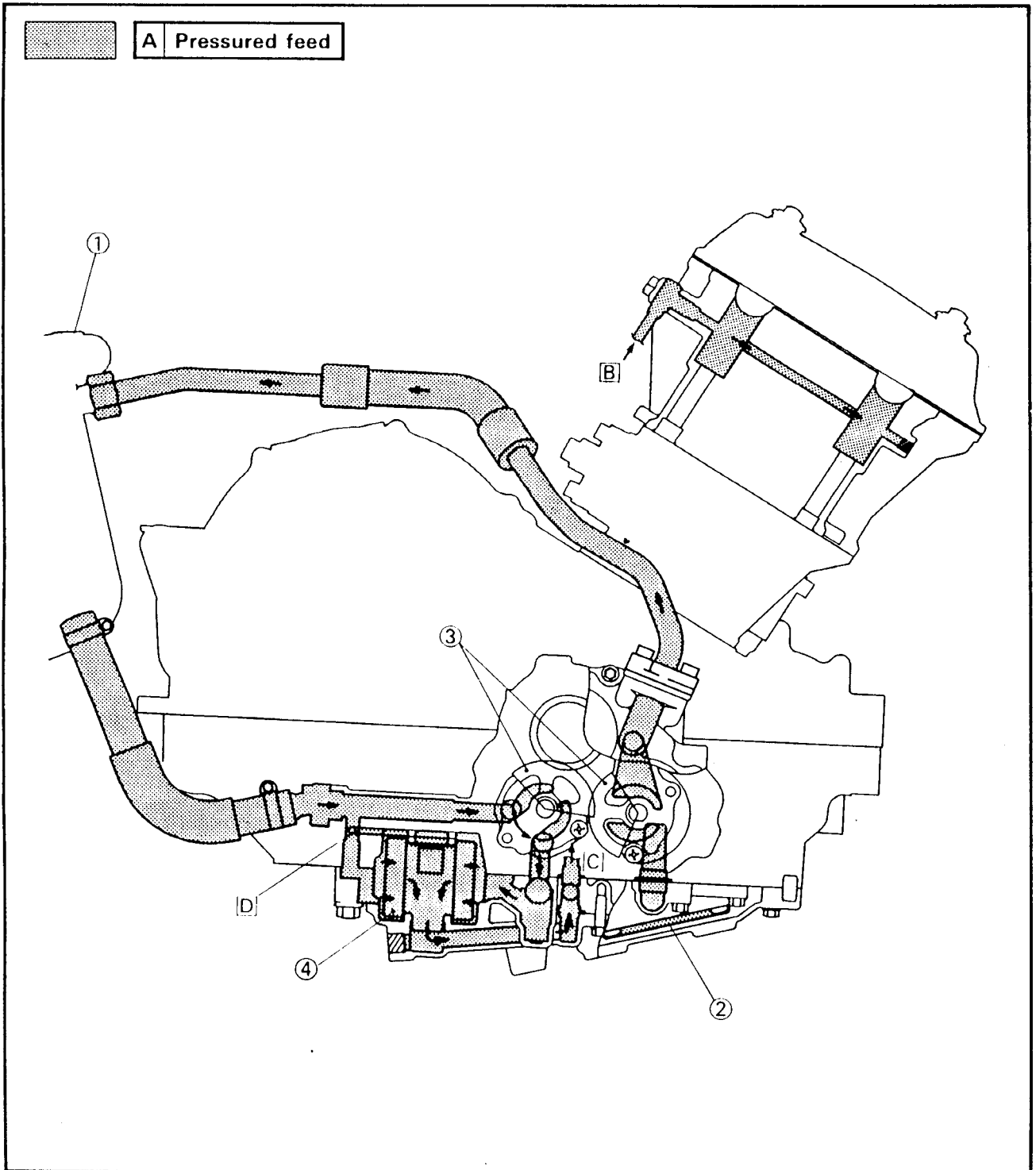



- ① Balancer
- ② Oil strainer
- ③ Oil pump
- ④ Rotor
- ⑤ Crankshaft

[B] To oil tank

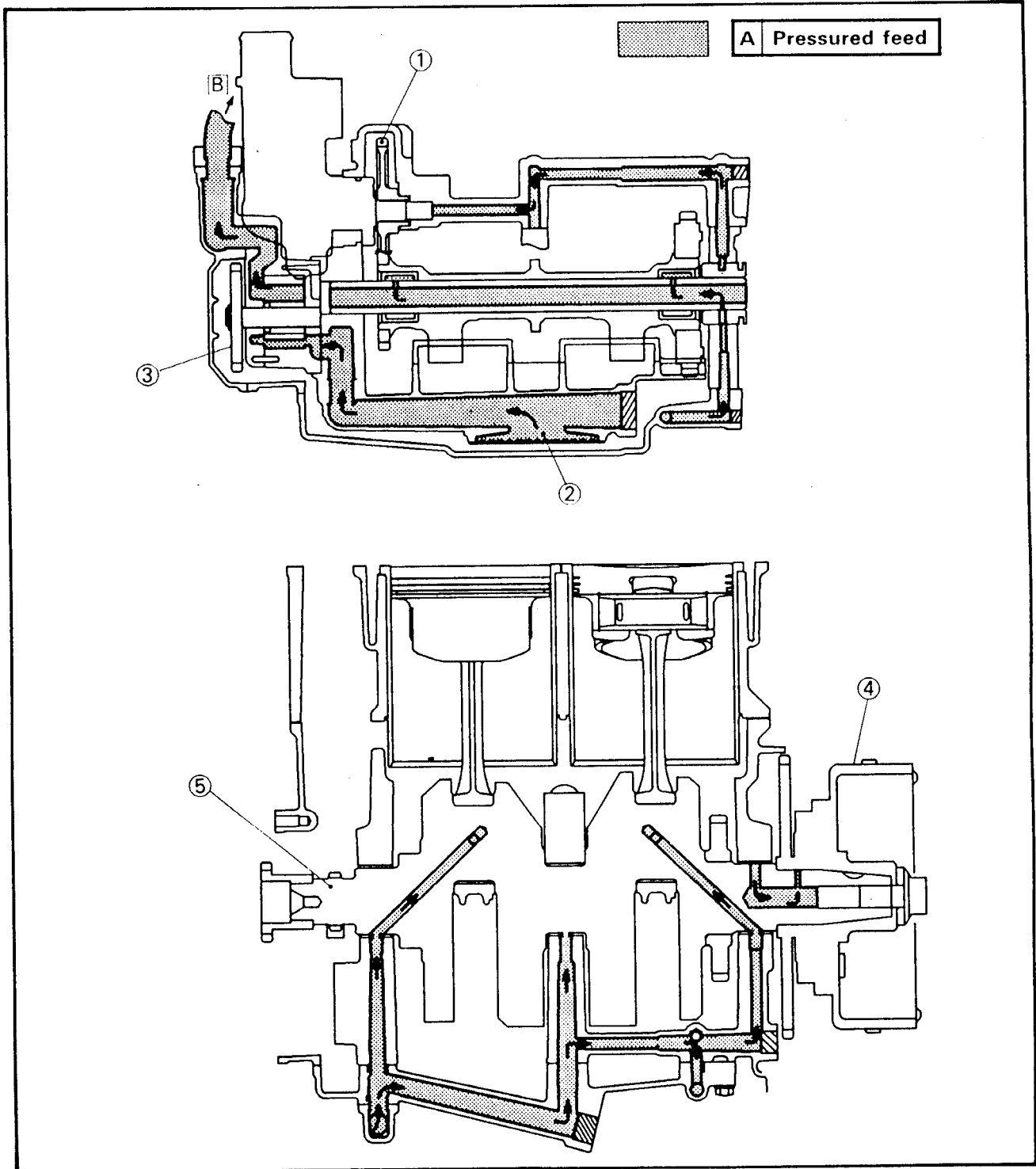

LUBRICATION DIAGRAM

SPEC



- ① Rear balancer
- ② Front balancer

- ⓑ To piston
- ⓒ To shift fork shaft
- ⓓ To cylinder head

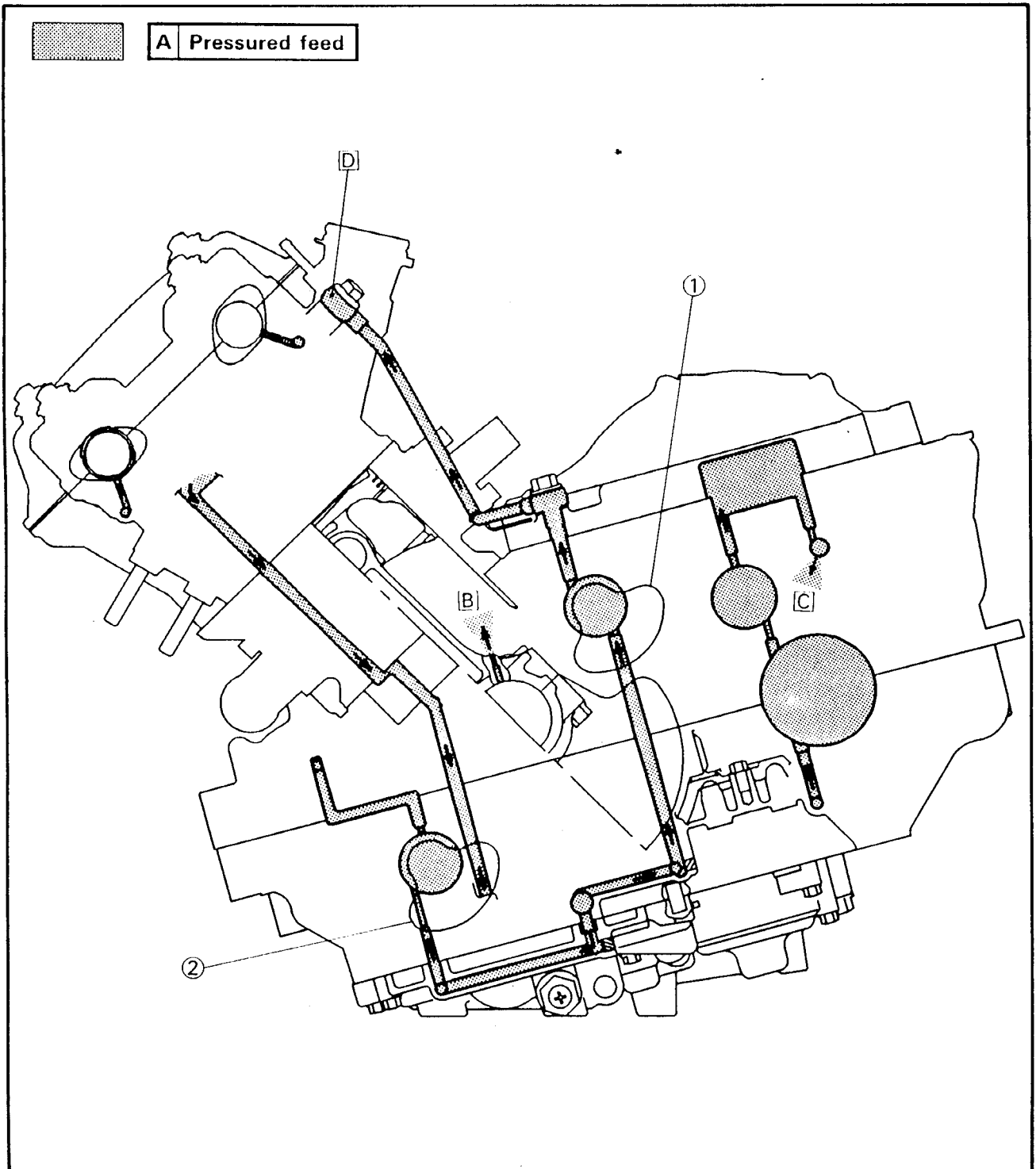

LUBRICATION DIAGRAM

SPEC



- ① Relief valve
- ② Oil pan
- ③ Balancer shaft
- ④ Oil pump
- ⑤ Cylinder head

- [B] From crankcase
- [C] To crankcase
- [D] To crankshaft

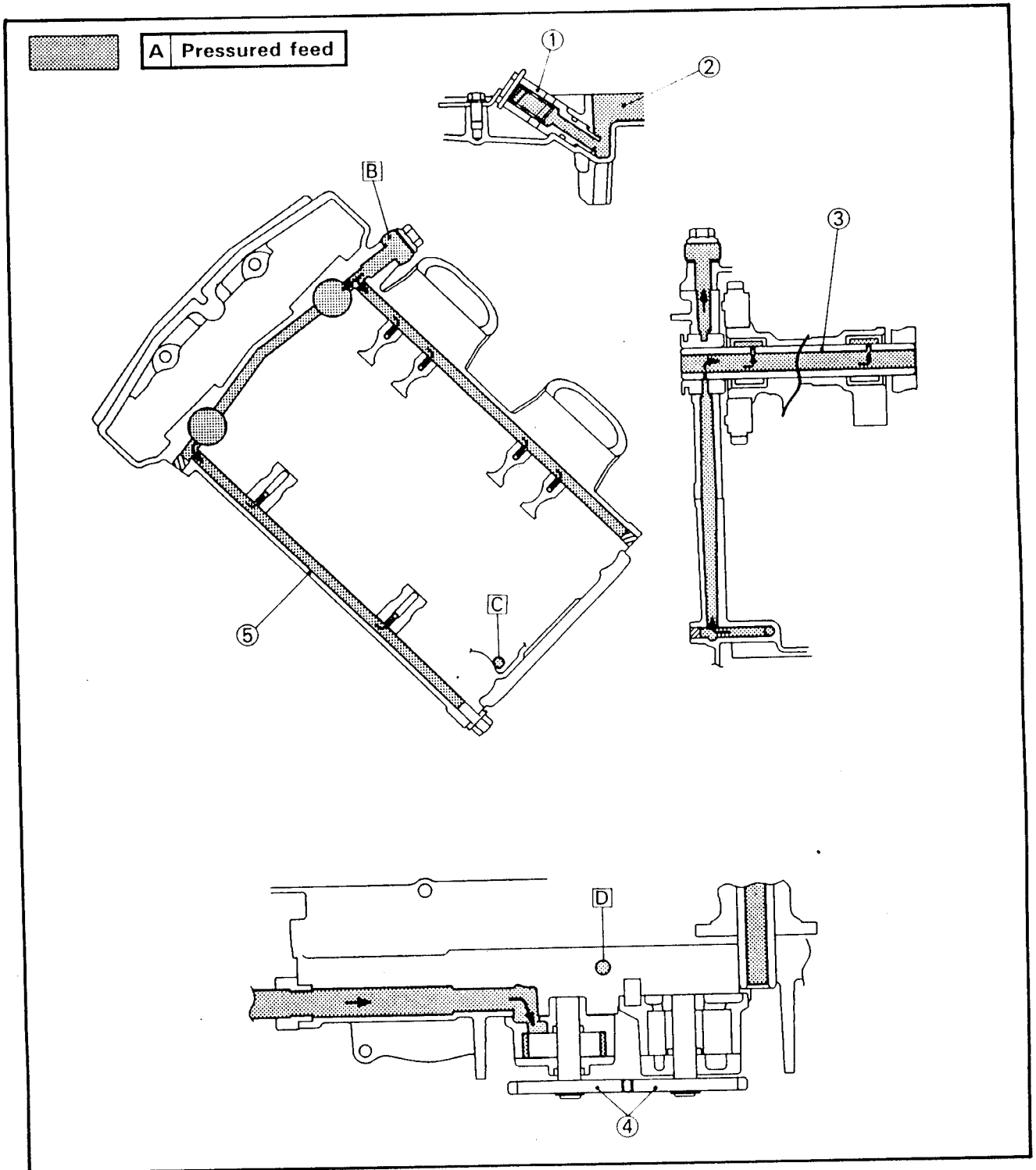

LUBRICATION DIAGRAM

SPEC



- ① Main axle
- ② Drive axle
- ③ Shift fork shaft

ⓑ From drain bolt

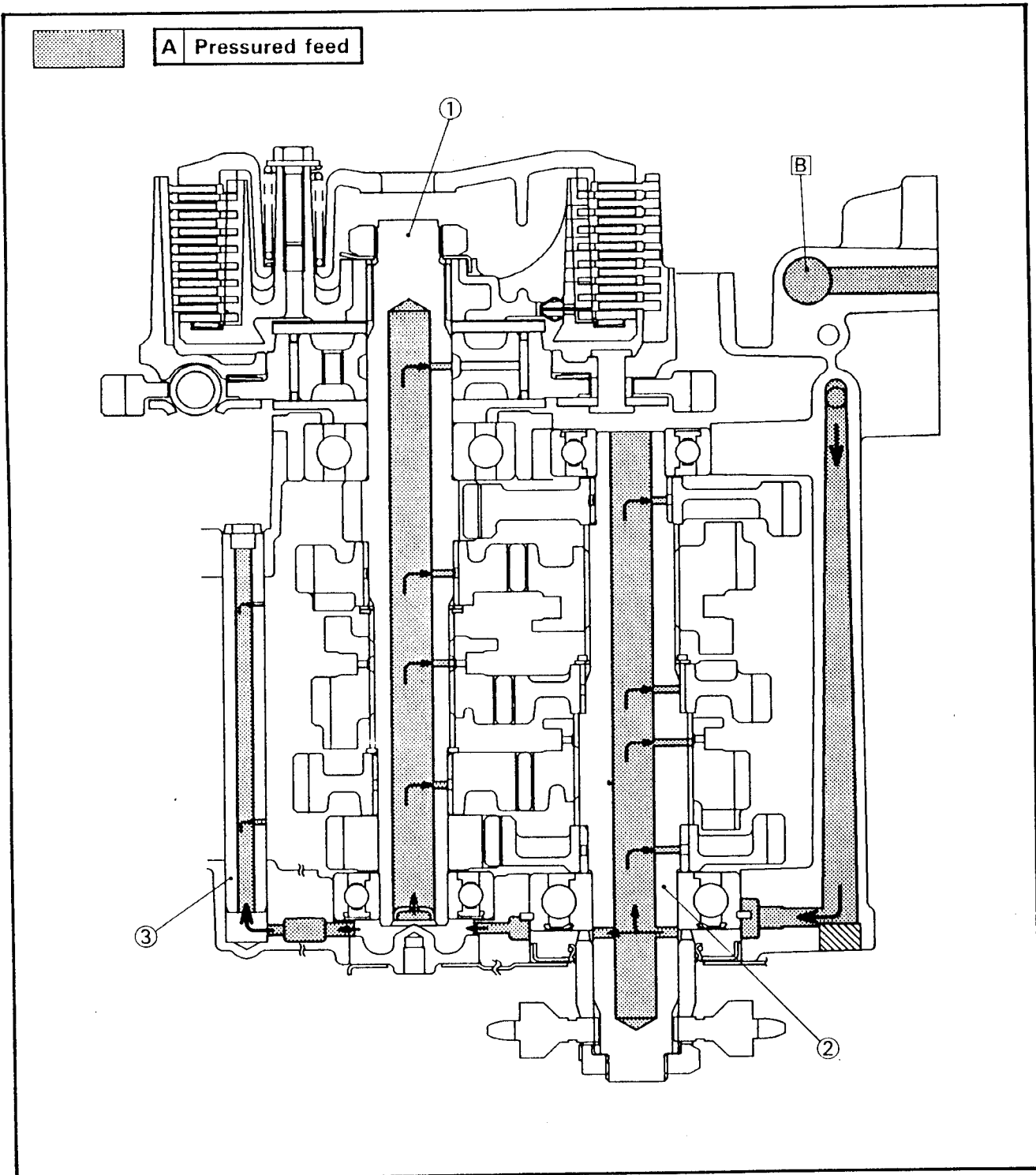



COOLANT DIAGRAM

- ① Radiator
- ② Water pump
- ③ Thermostat housing
- ④ Thermostat
- ⑤ Radiator cap

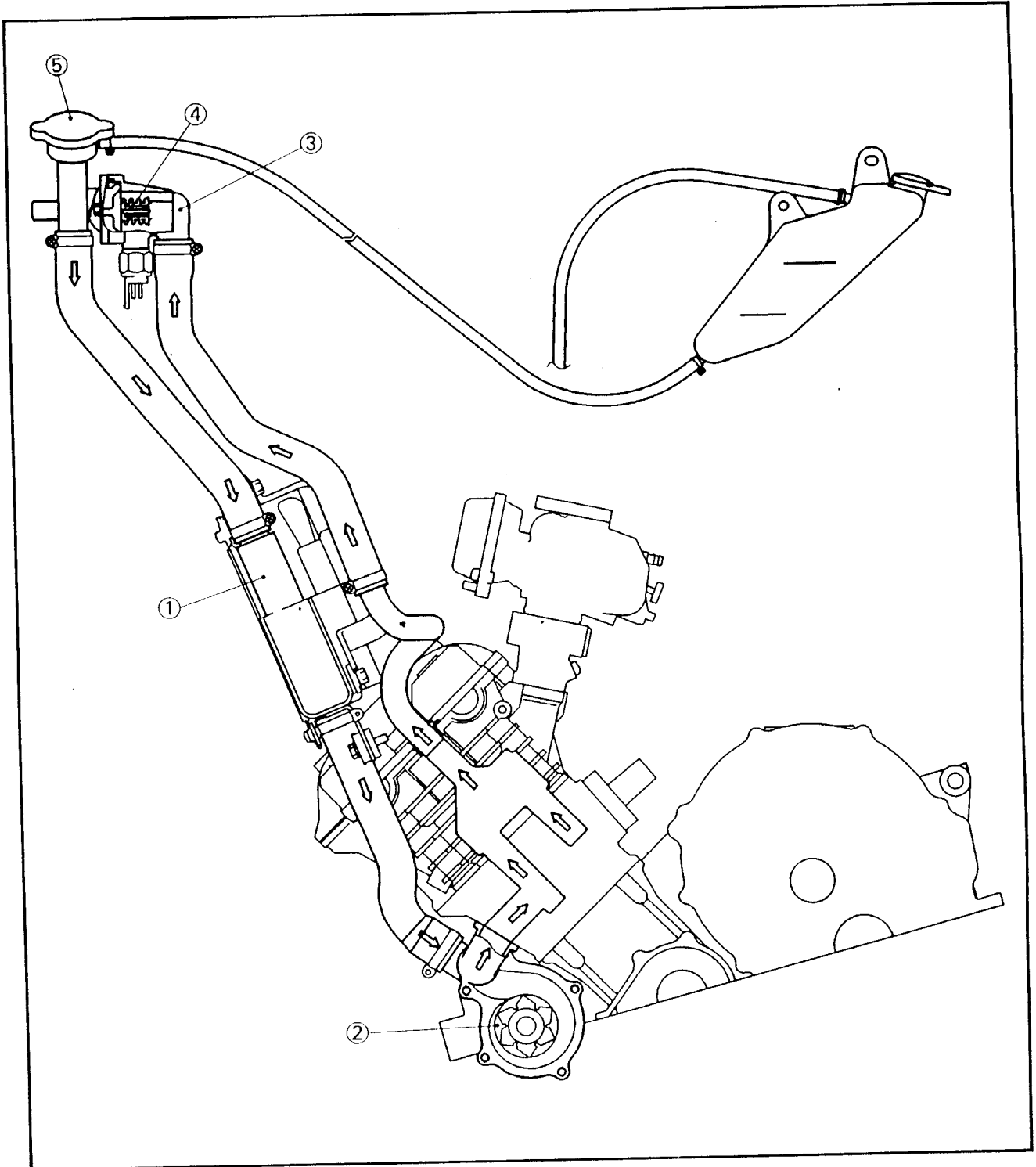



CABLE ROUTING

- ① Main switch lead
- ② Front brake switch lead
- ③ Handlebar switch lead (right)
- ④ Throttle cable
- ⑤ Band
- ⑥ Handlebar switch lead (left)
- ⑦ Clutch switch lead
- ⑧ Clutch cable
- ⑨ Guide

- ⑩ Headlight lead
- ⑪ Front flasher light lead (left)
- ⑫ Speedometer cable
- ⑬ Brake hose
- ⑭ Front flasher light lead (right)
- ⑮ Flasher relay

- [A] Clamp the headlight lead and the front flasher light leads.
- [B] To the auxiliary light.

- [C] After clamping the front flasher light leads, pass them into the hole of the front flasher stay.
- [D] Pass the speedometer cable through the guide.
- [E] To the flasher relay.

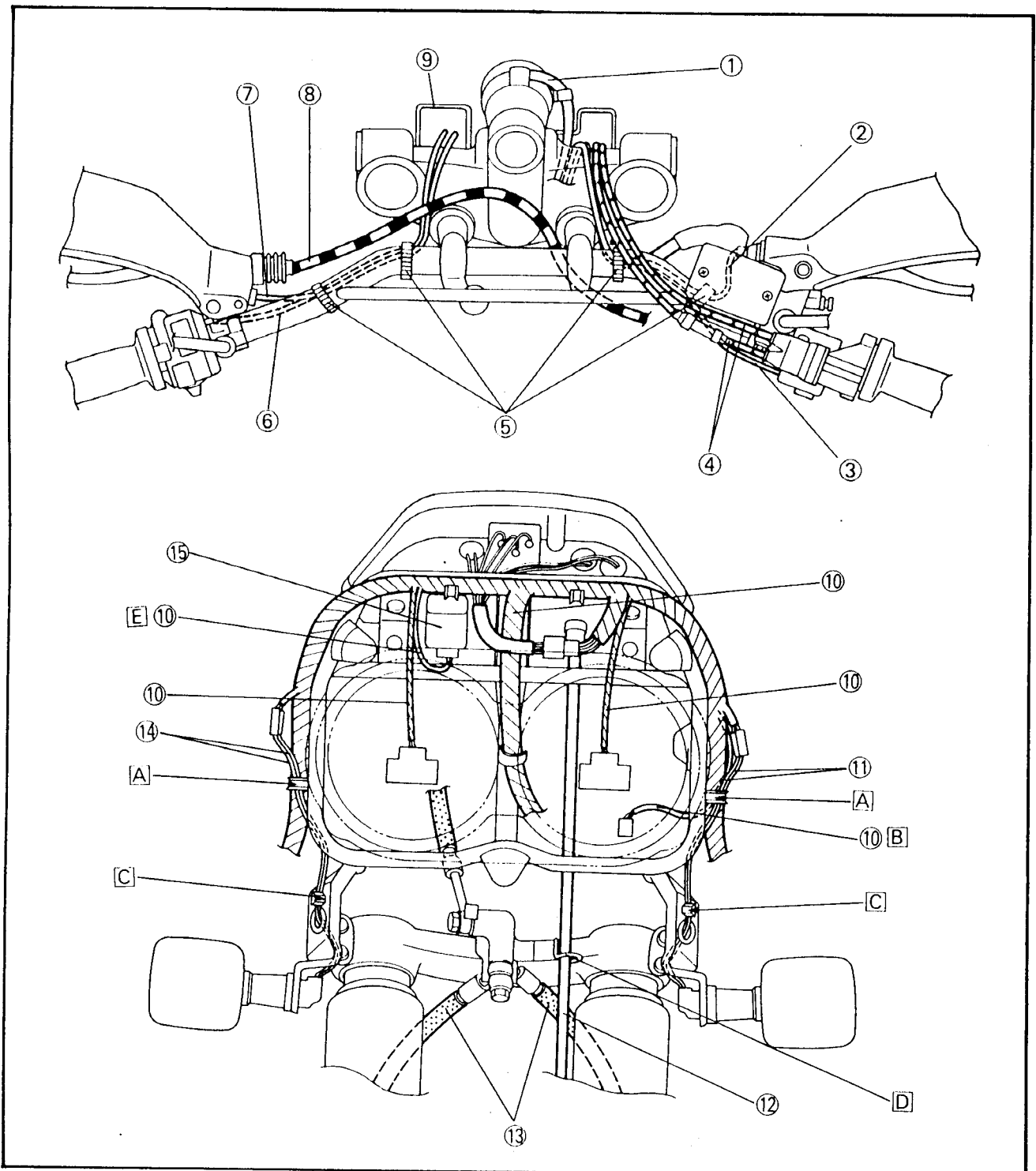

CABLE ROUTING

SPEC



- | | | |
|---------------------------------------|----------------------------------|-----------------|
| ① Handlebar switch lead (left) | ⑫ Battery positive lead | ⑳ Breather hose |
| ② Clutch switch lead | ⑬ Starter relay lead | ㉑ Vacuum hose |
| ③ Starter cable | ⑭ Wireharness | |
| ④ Air cleaner | ⑮ Rear flasher light lead | |
| ⑤ Clip | ⑯ Rear carrier | |
| ⑥ Clamp | ⑰ Air ventilation hose | |
| ⑦ Fuel hose | ⑱ Regulator plate | |
| ⑧ Starting circuit cut-off relay lead | ㉒ Rectifier/regulator | |
| ⑨ Neutral switch lead | ㉓ Coolant reservoir tank hose | |
| ⑩ A.C. magneto lead | ㉔ Starting circuit cut-off relay | |
| ⑪ Battery negative lead | ㉕ Sidestand switch | |

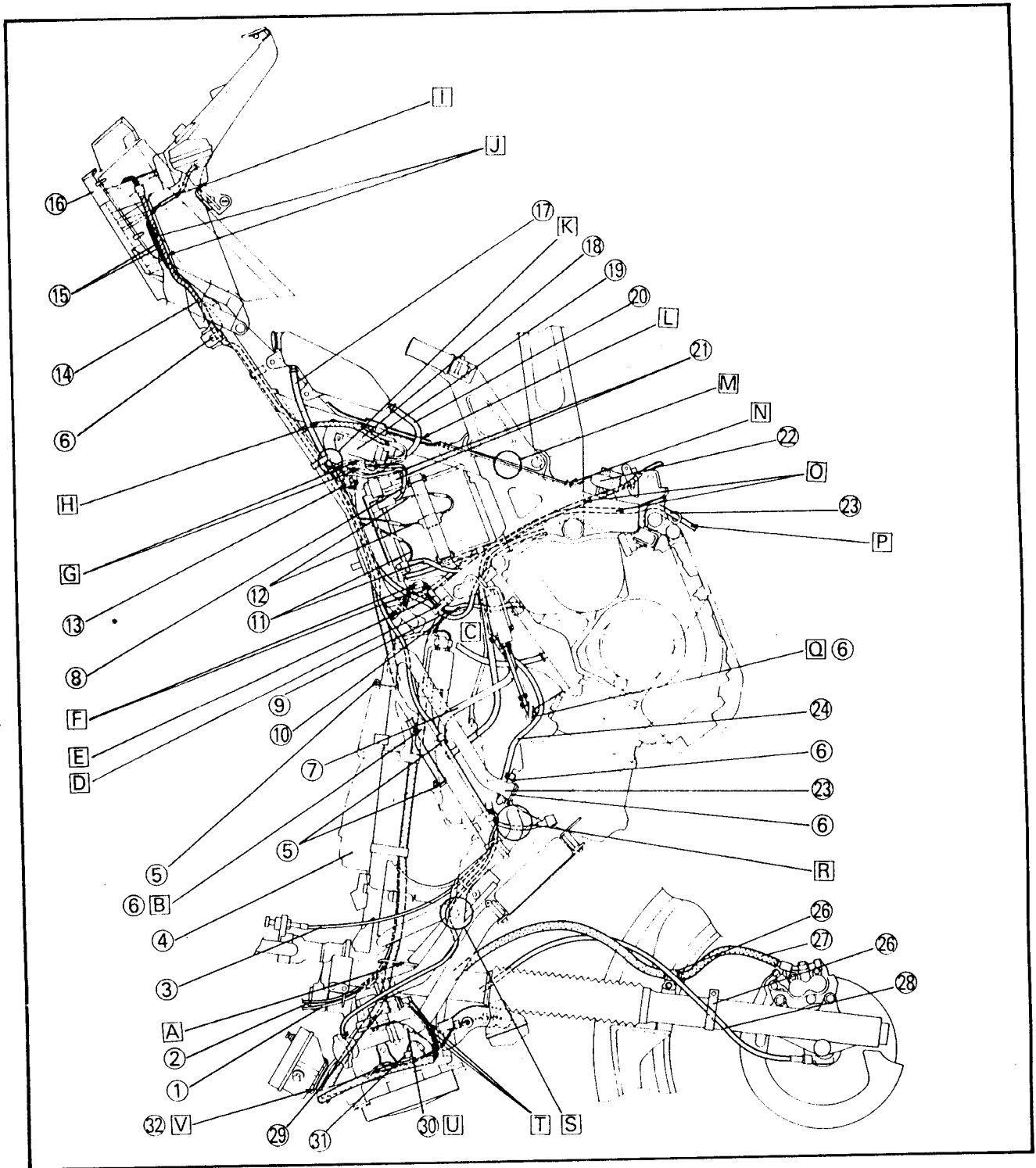

CABLE ROUTING

SPEC



- ⑫ Spark plug lead
- ⑬ Holder
- ⑭ Brake hose
- ⑮ Speedometer cable
- ⑯ Thermo unit lead
- ⑰ Headlight lead
- ⑱ Auxiliary light
- ⑲ Meter light lead
- [A] Pass the wireharness through the guide.
- [B] Clamp the air ventilation hoses.
- [C] To oil tank.
- [D] Clamp the starting motor lead, the neutral switch lead and A.C. magneto lead.
- [E] Connect the neutral switch lead to the wireharness.
- [F] Connect the A.C. magneto lead to the wireharness.
- [G] Connect the wireharness to the starter relay.
- [H] Pass the wireharness in front of the regulator plate.
- [I] Pass the rear flasher light lead, start on the inside of the hole of the license bracket and pass on its outside, and connect it to the wireharness.

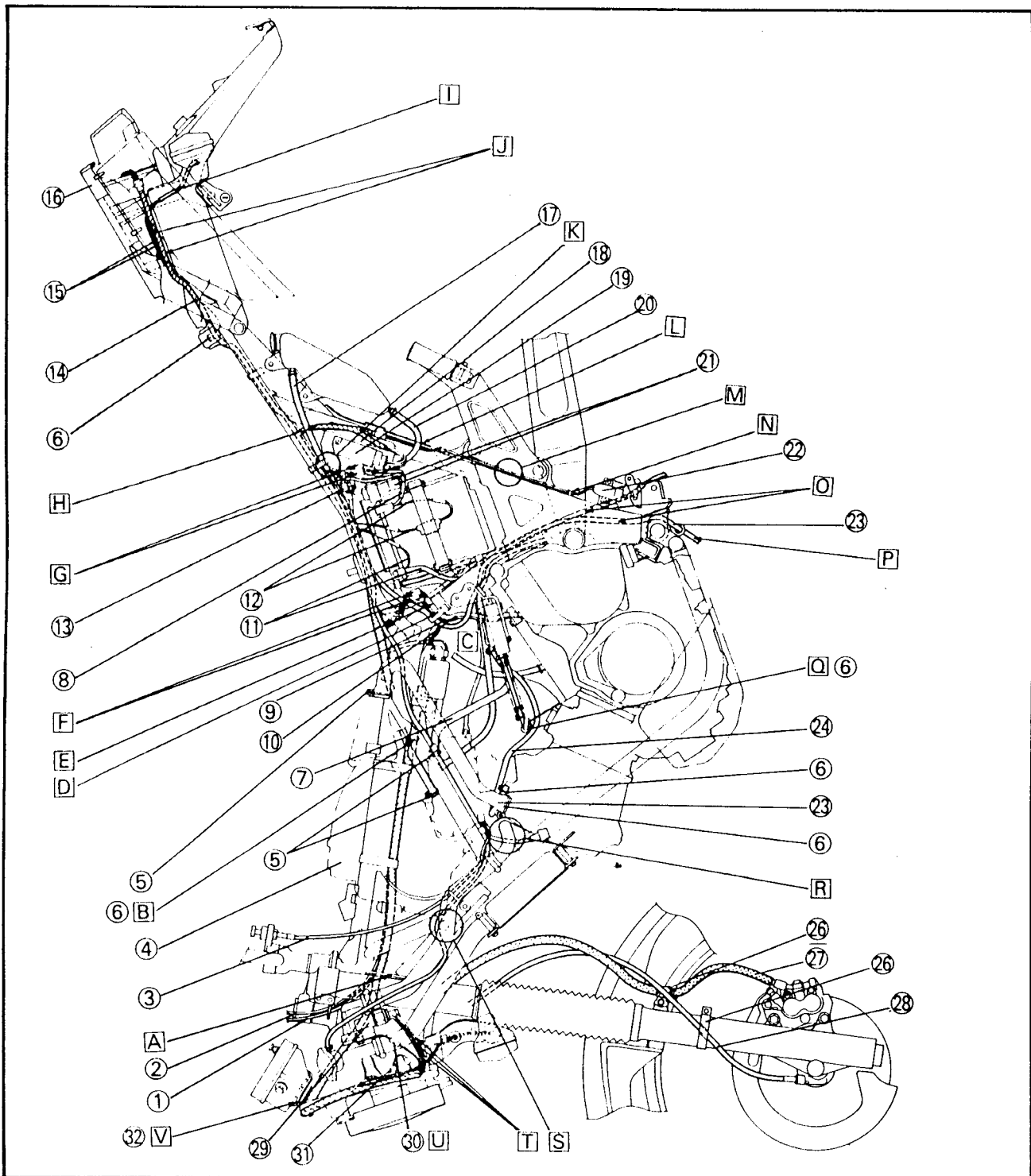



- J** Pass the wireharness and the rear flasher light leads (left and right) outside of the license bracket.
- K** Pass the air ventilation hose inside of the regulator plate and clamp it by band.
- L** Pass the coolant reservoir tank hose through the hole of the battery box.
- M** Do not pinch the sidestand switch lead with the rear footrest.
- N** Clamp the sidestand switch lead.

- O** Pass the breather hoses between the left side of the relay arm and in front of the swingarm.
- P** Pass the breather hose through the hole of the bracket (left side).
- Q** Pass the fuel hose through the clamp.
- R** Pass the spark plug lead over the regulator hose. Be sure both spark plug leads do not contact the cooling fan.

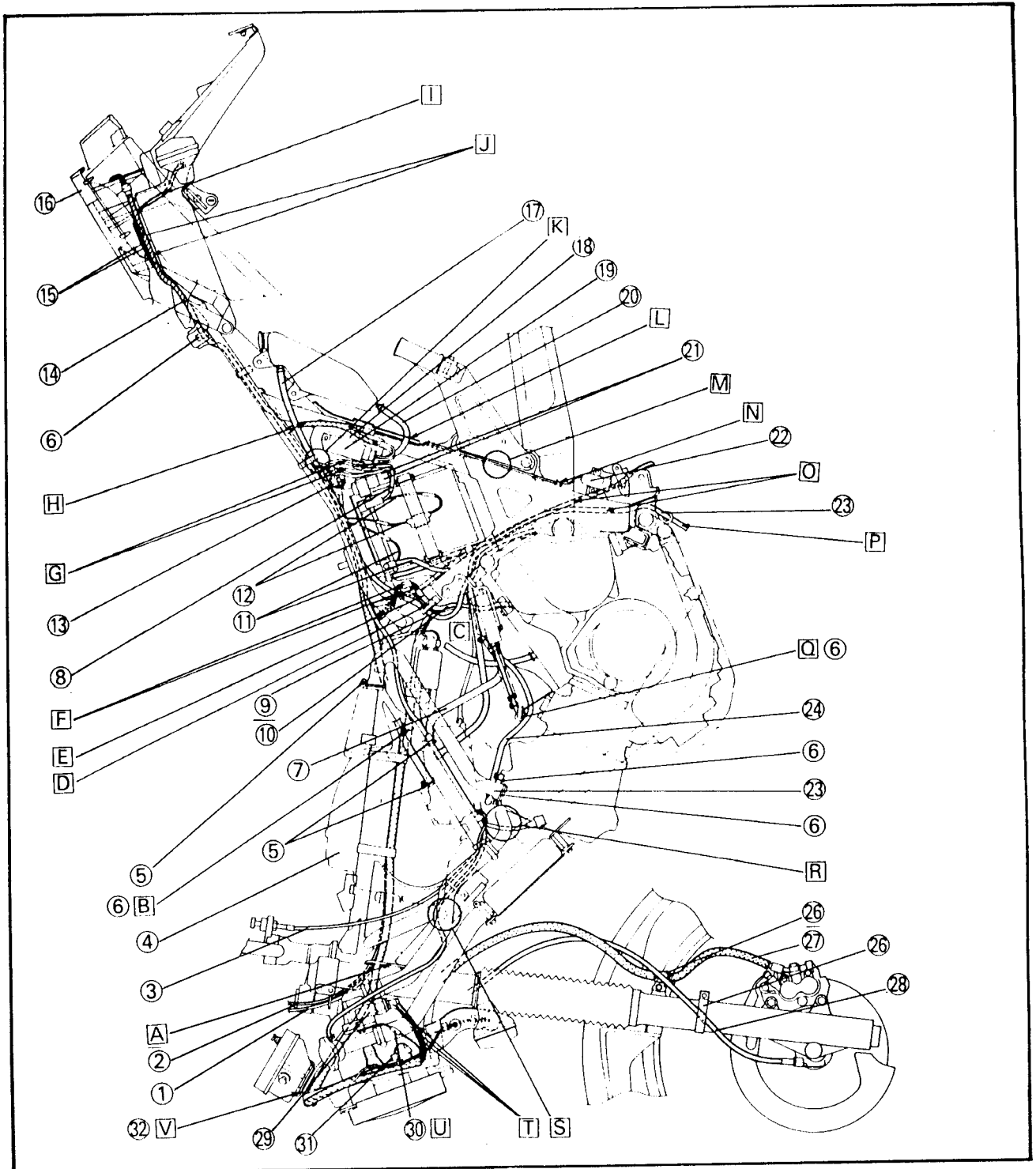

CABLE ROUTING

SPEC



- S Pass the coolant reservoir hose over the side cowling bracket.
- T Pass the thermo unit leads outside of the regulator hose and then connect to the thermo unit.
- U Connect the headlight lead and the thermo unit lead outside of the regulator hose.
- V Pass the meter light lead outside of the meter.

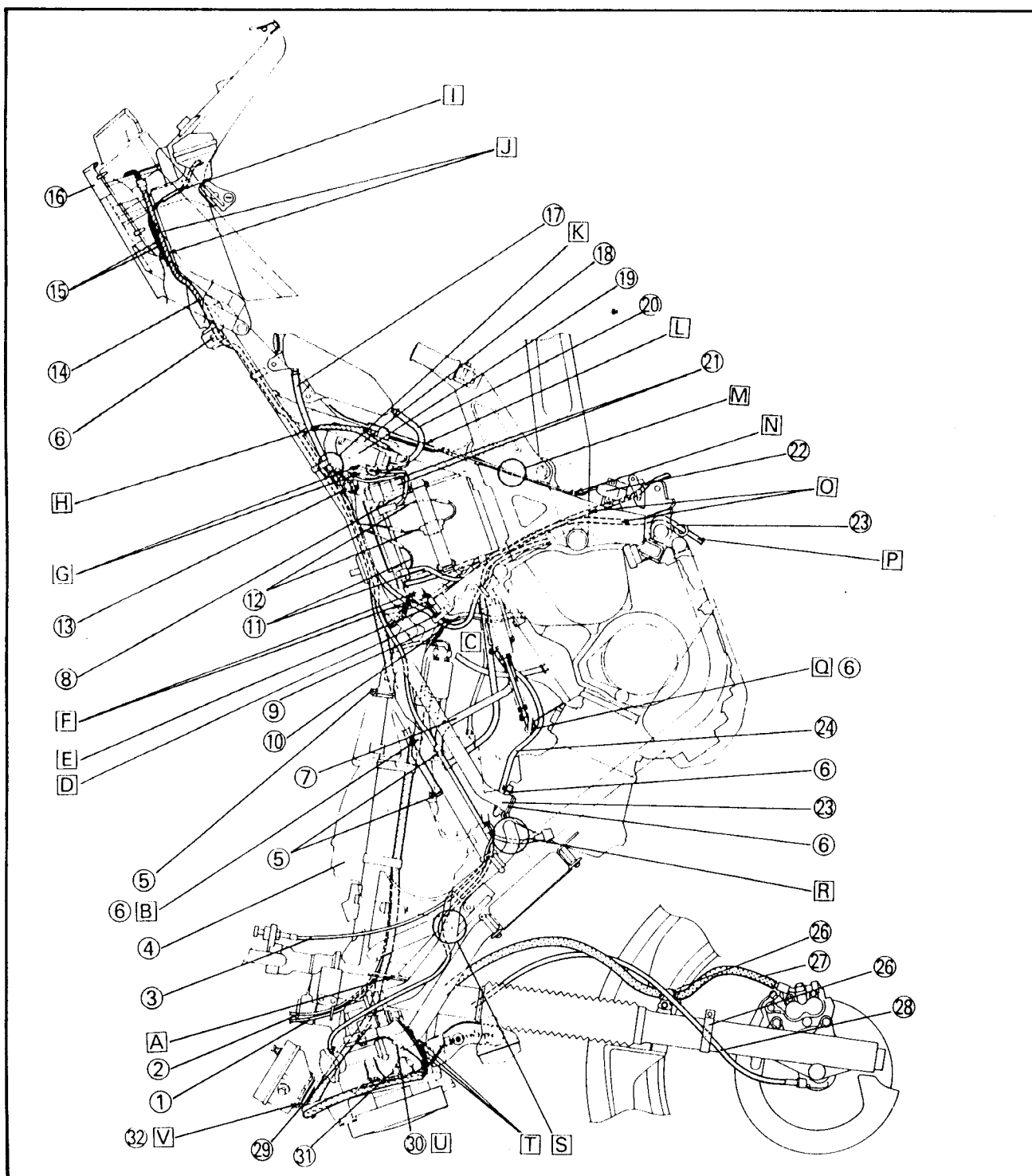

CABLE ROUTING

SPEC



- | | | |
|-----------------------------------|----------------------------------|---------------------------------------|
| ① Fan motor lead | ⑫ Rear carrier | ⑳ Fuel pump assembly |
| ② Cooling fan | ⑬ Rear flasher light lead (left) | ㉑ Fuel hose (from fuel tank) |
| ③ Band | ⑭ Wireharness | ㉒ Spring |
| ④ Coolant reservoir tank hose | ⑮ Battery box | ㉓ Vacuum hose (from carburetor joint) |
| ⑤ Starter cable | ⑯ Starting motor lead | |
| ⑥ Clutch cable | ⑰ Air ventilation hose | |
| ⑦ Clamp | ⑱ Neutral switch lead | |
| ⑧ Air ventilation hose | ⑲ A.C. magneto lead | |
| ⑨ Oil tank | ⑳ Spark plug lead | |
| ⑩ Rear flasher light lead (right) | ㉑ Fuel hose (from carburetor) | |
| ⑪ Tail/brake light lead | ㉒ Clip | |

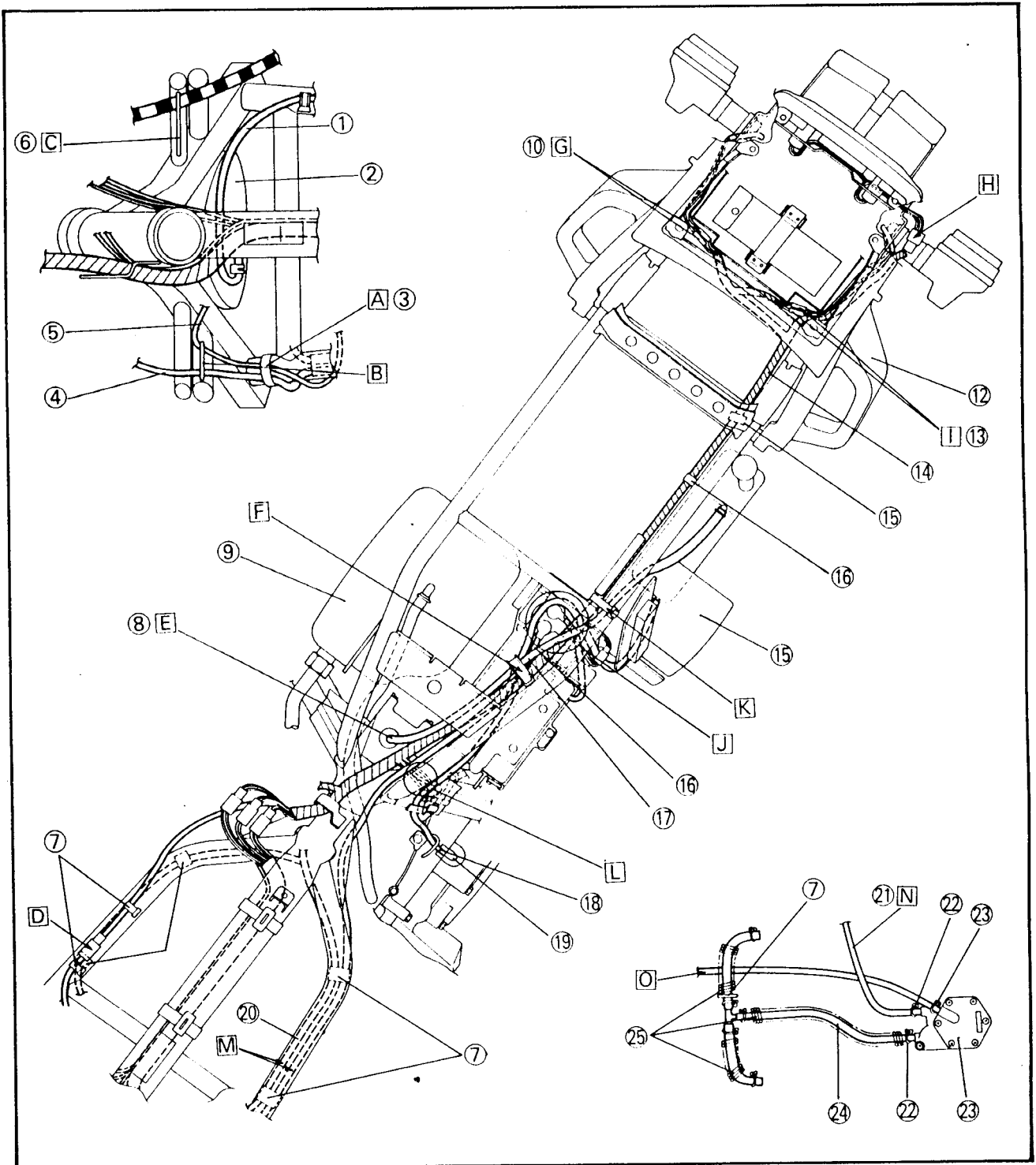

CABLE ROUTING

SPEC



- A Clamp the starter cable and reservoir tank hose in front of the cross pipe.
- B Pass the coolant reservoir tank hose and starter cable through the guide.
- C Pass the clutch cable through the guide.
- D Clamp the fan motor leads over the frame.
- E Pass the air ventilation hose through the hole of the bracket.
- F Clamp the wireharness, air ventilation hose, coolant reservoir tank hose and starter motor lead with the former two on the upper side and the latter two on the lower side.
- G Connect the rear flasher light lead (right) to the wireharness.
- H Connect the tail/brake light lead to the wireharness.

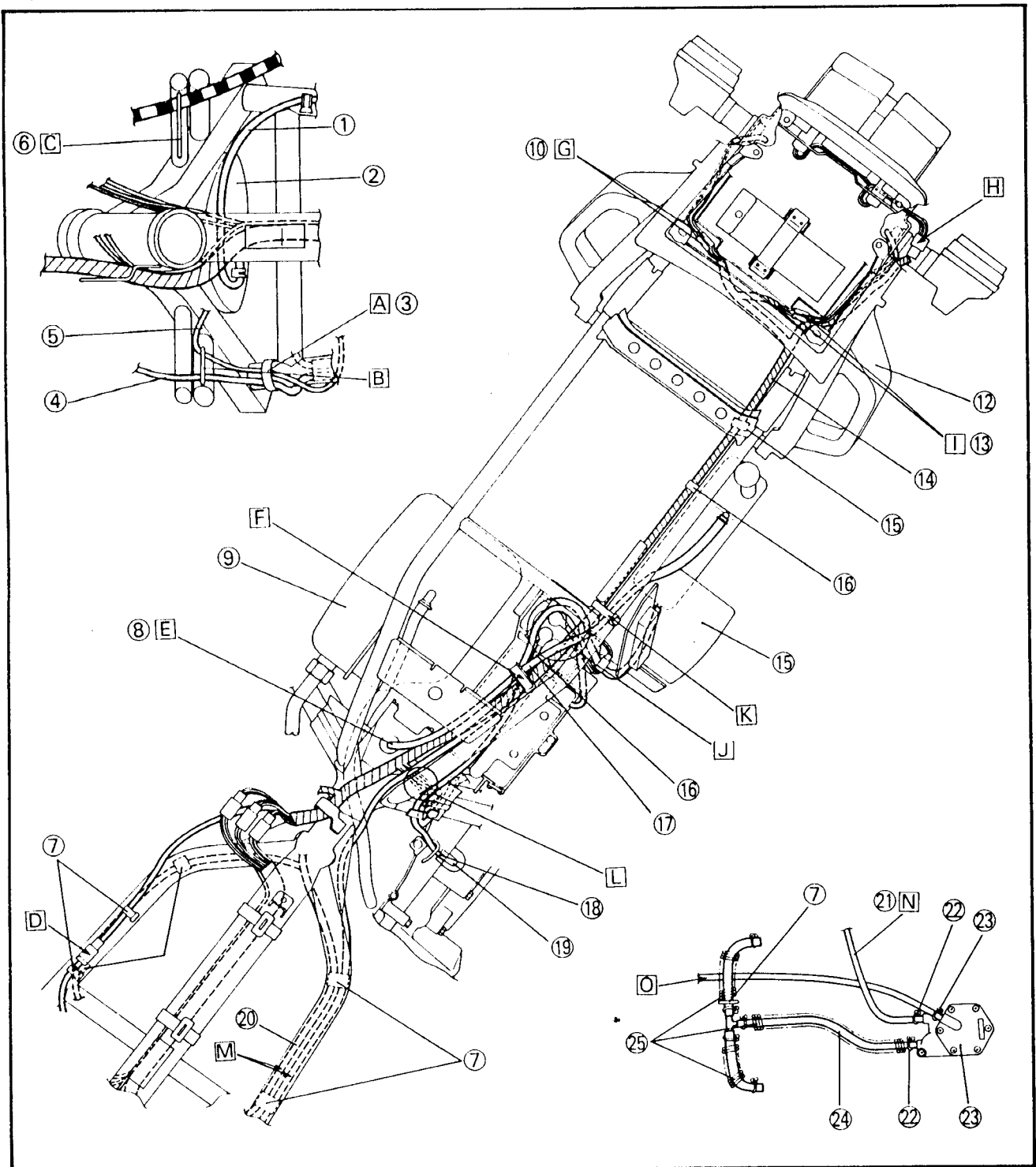

- I Connect the rear flasher light lead (left) to the wireharness.
- J Pass the coolant reservoir tank hose right side of the starter relay.
- K Clamp the wireharness and the air ventilation hose.
- L Pass the leads under the frame.
- M Clamp the coolant reservoir tank hose (outside) and the spark plug lead (inside).
- N Pass the fuel hose over the vacuum hose.
- O Pass the vacuum hose under the fuel hose.

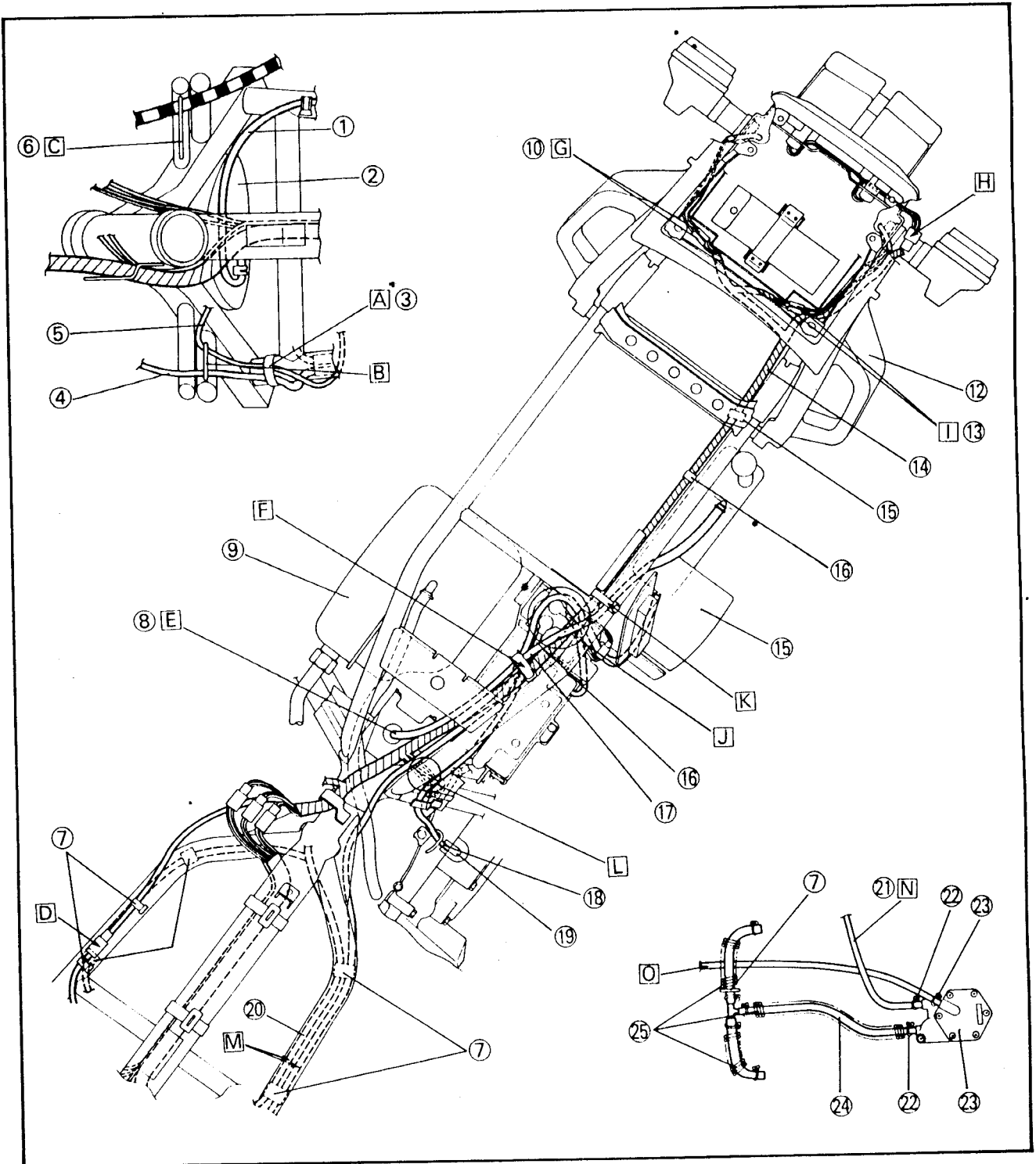

CABLE ROUTING

SPEC



- | | |
|-----------------------------------|----------------------------------|
| ① Ignitor unit | ⑬ Master cylinder reservoir tank |
| ② Holder | ⑭ Oil tank breather hose |
| ③ Horn | ⑮ Wireharness |
| ④ Fan motor lead | ⑯ Ignition coil |
| ⑤ Spark plug lead | ⑰ Band |
| ⑥ Spark plug cap | ⑱ Clutch cable |
| ⑦ Rear brake switch | ⑲ Brake hose |
| ⑧ Clamp | ⑳ Throttle cable |
| ⑨ Rear brake switch lead | ㉑ Front brake switch lead |
| ⑩ Master cylinder (rear brake) | ㉒ Handlebar switch lead (right) |
| ⑪ Rear brake hose | ㉓ Main switch lead |
| ⑫ Master cylinder reservoir hose. | |

